

TYPE: -SHB

# CLEAR FLOW GAUGE

OPERATION MANUAL

※Applied to (-NF) model: Flange type

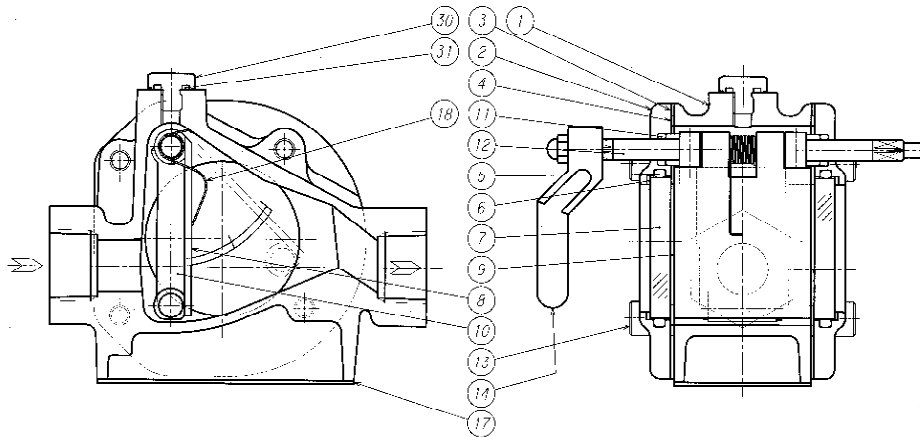

PARTS LIST			
MARK	PARTICULAR	Q	REMARK
1	BODY	1	
2	COVER	2	
3	GASKET	2	
4	O-RING	2	
5	O-RING	2	
6	CUSHON GASKET	2	
7	SIGHT GLASS	2	REINFORCED
8	FLAPPER	1	
9	BRUSH	2	
10	BRUSH HOLDER	2	
11	O-RING	2	
12	SPINDLE	1	
13	----		
14	HANDLE	1	
22	SPRING	1Set	
30	PLUG	1	
31	O-RING	1	

※Refer to the drawing for materials.  
There may be no ⑫spring by specification.

### Structure:

The check of a flow and fluid is possible by a flapper's angle and sight glass scale.

It is using a wiper operation,

1. Cleaning of ⑦sight glass
2. Prevention from adherence of ⑧flapper and ⑫spindle
3. Prevention from garbage adhesion to ⑧flapper ... etc, is very convenient.

### Piping connection:

1. Keep enough working space for maintenance and cleaning.
2. Do not force to install with different pipe fittings or sizes.
3. Install correctly between pipes to avoid pipe resistance.

### Piping image:

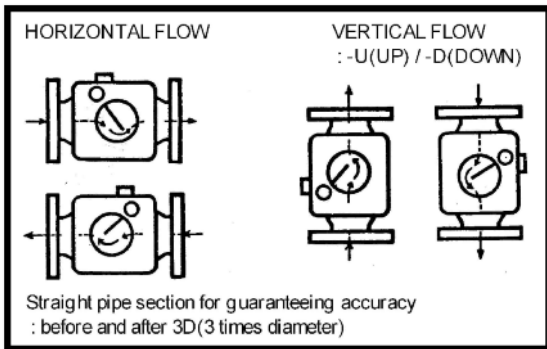

The wrong piping causes breakage of the product.

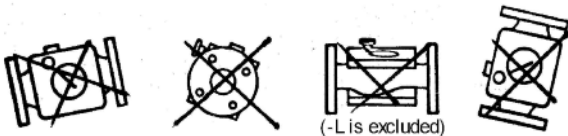

\* Available for installing TYPE: -Nf (NON FLAPPER) in any piping directions and flow directions.

### Wiper operation:

If ⑭handle is operated, a wiper will move.

1. Wiper operation drops the dirt of ⑦sight glass. Before becoming dirty, it is effective if it carries out periodically.
2. Wiper operation is made to open ⑧flapper (is automatic when closed). Therefore, you can check whether the flapper action is normal.

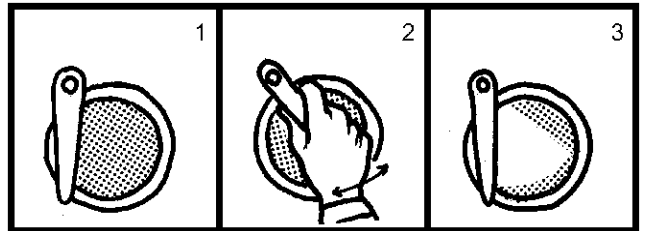

### Air relief plug:

In horizontal piping, air may collect on the upper part in ①body.

In that case, please loosen ⑩plug and extract air.

Measurement directions are not right if air is being mixed.

### Maintenance and Cleaning:

When dirt and garbage unremovable by wiper operation, please carry out maintenance and cleaning in the following direction.

1. Fasten the valve of an entrance and an exit so that fluid does not flow in during maintenance and cleaning.
2. Remove the nut of ⑭handle and remove from ⑫spindle.
3. Remove the bolt which has fastening ①body and ②cover.
4. Remove ②cover so that ⑫spindle remains in ①body.  
\*At this time, ⑦sight glass is united with ②cover.
5. Remove ⑧flapper and ⑫spindle ⑫spring, and clean an inside.  
\*When you remove parts, please treat carefully.  
Modification of ⑫spring leads to the error of measurement directions.
6. It is an end above.

Please perform the assembly to the contrary of a decomposition procedure.

Make sure there is no leakage after all the work.

\*When you decompose, please also carry out exchange of a gasket and O ring.

## TAIYO VALVE MFG. CO., LTD.